

TAPPING SLEEVE - PLAN

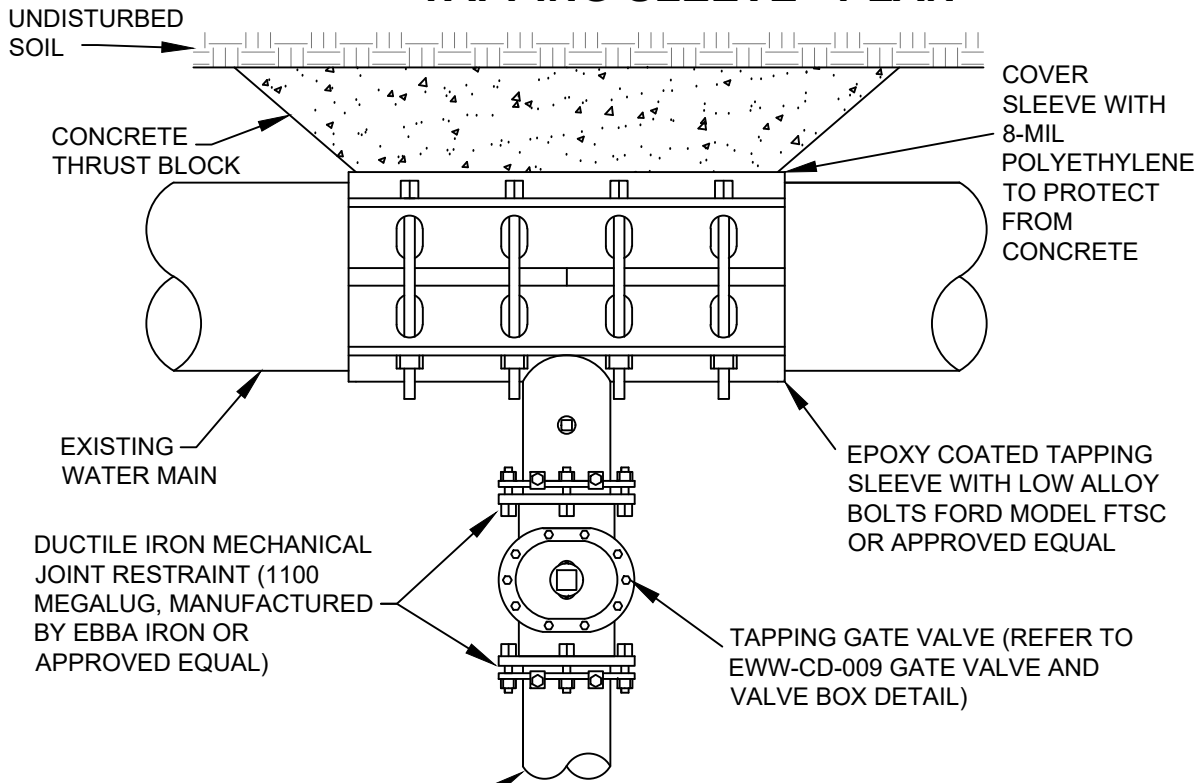

TAPPING SLEEVE - ELEVATION

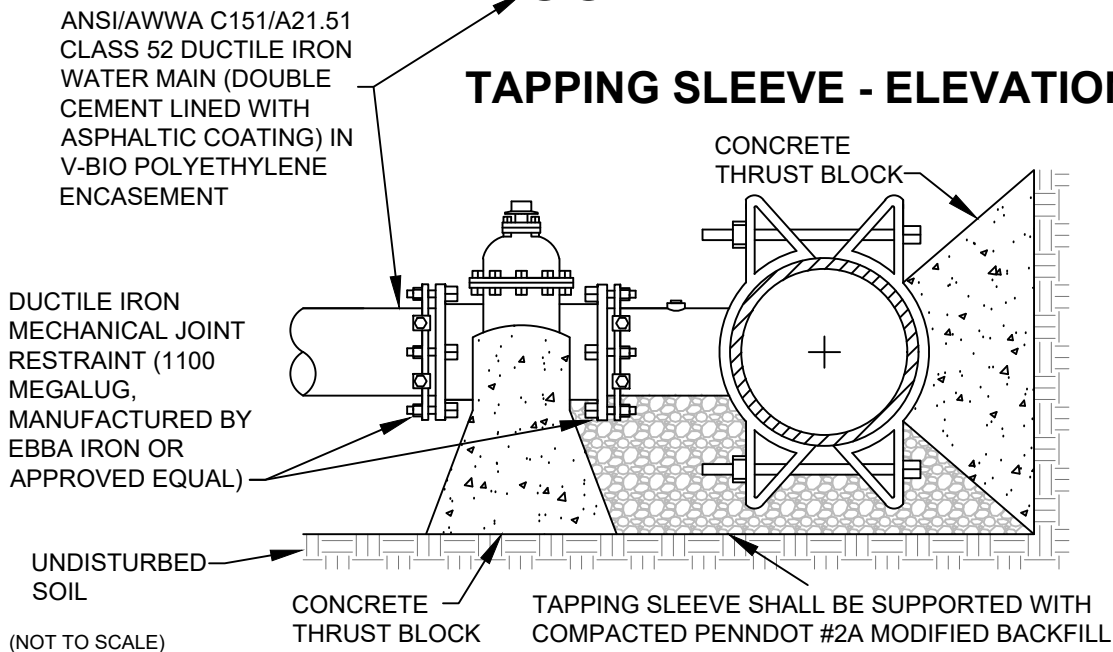

NOTES:

1. TAPPING SLEEVE IS APPROVED FOR USE WHERE WORKING PRESSURES ARE UNDER 150 PSI. CONSULT EWW ENGINEERING TO DETERMINE WORKING PRESSURES.
2. PENNDOT CLASS A CONCRETE SHALL BE USED FOR THRUST BLOCKS.
3. CONCRETE MUST BEAR UPON UNDISTURBED SOIL. MECHANICAL JOINTS AND CONCRETE ARE TO BE USED FOR TAPPING SLEEVES.
4. ROUGH FORMS SHALL BE USED TO CONTAIN CONCRETE FOR THRUST BLOCKS. MECHANICAL JOINTS ARE NOT TO BE COVERED.
5. ALLOW POURED CONCRETE THRUST BLOCKS TO SET PRIOR TO BACKFILLING.
6. ALL PIPE AND FITTINGS TO BE WRAPPED IN POLYETHYLENE ENCASEMENT.
7. ALL FITTINGS ARE TO BE MECHANICALLY RESTRAINED.
8. ALL BOLTS, NUTS, AND WASHERS EXPOSED TO DIRECT BURY CONDITIONS SHALL BE LOW ALLOY STEEL. AFTER ASSEMBLY ALL BOLTS, NUTS, AND WASHERS SHALL BE COMPLETELY COATED WITH SPRAY ON CORROSION PROTECTION AND BOLTS SHALL BE EQUIPPED WITH SACRIFICIAL ZINC ANODE CAPS (MANUFACTURED BY TRUMBULL OR APPROVED EQUAL).
9. LOCK TYPE GASKETS (U.S. PIPE FIELD LOCK GASKETS OR APPROVED EQUAL) SHALL BE INSTALLED FOR 40' AFTER THE TAPPING VALVE.
10. ALL PIPES, FITTINGS, AND FIXTURES IN CONTACT WITH POTABLE WATER SHALL BE LEAD FREE PER THE REDUCTION OF LEAD IN DRINKING WATER ACT AND NSF/ANSI STANDARD 61 (NSF-61). LEAD FREE IS DEFINED AS CONTAINING NOT MORE THAN A WEIGHTED AVERAGE OF 0.25 PERCENT LEAD WHEN USED WITH RESPECT TO THE WETTED SURFACES OF PIPES, PIPE FITTINGS, PLUMBING FITTINGS, AND FIXTURES.
11. ALL MATERIALS FURNISHED AND INSTALLED MUST COMPLY WITH THE PENNSYLVANIA STEEL PRODUCTS PROCUREMENT ACT.
12. ANY MODIFICATION MUST BE APPROVED BY THE EWW ENGINEERING DEPARTMENT IN ADVANCE.

MINIMUM THRUST BLOCK SIZES

EXISTING MAIN SIZE	IN	4"	6"	8"	10"	12"	16"
THRUST BLOCK AREA	SF	1.1	2.2	3.7	5.5	7.7	13.4
EXISTING MAIN SIZE	IN	20"	24"	30"	36"		
THRUST BLOCK AREA	SF	20.7	29.4	24.2	34.6		

TAPPING SLEEVE (LIVE TAP) WITH THRUST BLOCK

DRAWN BY: RD APPROVED BY: CP
 DATE: FEB 2020 EWW - CD - 008

ERIE WATER WORKS
 240 West 12th Street
 Erie, PA 16501
engineering@eriewaterworks.org

