

RESTRAIN ALL JOINTS FOR 40' BEYOND THE END OF THE CASING PIPE. LOCK TYPE GASKETS (U.S. PIPE FIELD LOCK GASKETS OR APPROVED EQUAL)

RESTRAIN ALL JOINTS WITHIN CASING PIPE UTILIZING LOCK TYPE GASKETS (U.S. PIPE FIELD LOCK GASKETS OR APPROVED EQUAL).

10' MAX OR AS DIRECTED BY CARRIER MANUFACTURER TO SUPPORT CARRIER PIPE MATERIAL

NEOPRENE RUBBER END SEAL (MANUFACTURED BY CASCADE WATERWORKS MFG. OR APPROVED EQUAL).

STEEL CASING PIPE ASTM 53

CASING SPACERS (CASCADE CASING SPACERS MODEL CCS AS MANUFACTURED BY CASCADE WATERWORKS MFG. OR APPROVED EQUAL)

STAINLESS STEEL BANDS

304 STAINLESS STEEL STUD WASHERS AND HEX NUTS

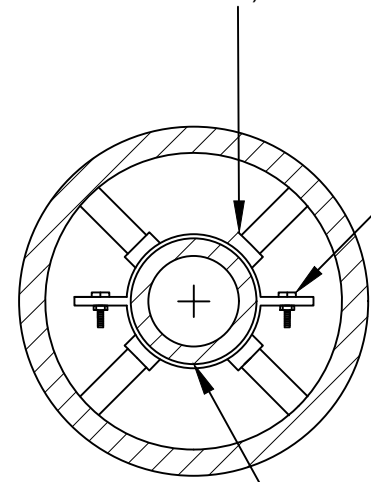

MINIMUM CASING PIPE SIZE (AND CASING THICKNESS*)	
20" WATER MAIN	- 36" CASING (0.75")
16" WATER MAIN	- 30" CASING (0.688")
12" WATER MAIN	- 24" CASING (0.688")
8" WATER MAIN	- 16" CASING (0.50")
6" WATER MAIN	- 12" CASING (0.50")
4" WATER MAIN	- 10" CASING (0.50")

\* BASED ON SCHEDULE 40 WALL THICKNESS WITH 0.5" AS MINIMUM SIZE.

ANSI/AWWA C151/A21.51 CLASS 52 DUCTILE IRON WATER MAIN (DOUBLE CEMENT LINED WITH ASPHALTIC COATING) IN V-BIO POLYETHYLENE ENCASEMENT

(NOT TO SCALE)

NOTES:

1. ALL BOLTS, NUTS, AND WASHERS EXPOSED TO DIRECT BURY CONDITIONS SHALL BE LOW ALLOY STEEL. AFTER ASSEMBLY ALL BOLTS, NUTS, AND WASHERS SHALL BE COMPLETELY COATED WITH SPRAY ON CORROSION PROTECTION AND BOLTS SHALL BE EQUIPPED WITH SACRIFICIAL ZINC ANODE CAPS (MANUFACTURED BY TRUMBULL OR APPROVED EQUAL).
2. ALL PIPES, FITTINGS, AND FIXTURES IN CONTACT WITH POTABLE WATER SHALL BE LEAD FREE PER THE REDUCTION OF LEAD IN DRINKING WATER ACT AND NSF/ANSI STANDARD 61 (NSF-61). LEAD FREE IS DEFINED AS CONTAINING NOT MORE THAN A WEIGHTED AVERAGE OF 0.25 PERCENT LEAD WHEN USED WITH RESPECT TO THE WETTED SURFACES OF PIPES, PIPE FITTINGS, PLUMBING FITTINGS, AND FIXTURES.
3. ALL MATERIALS FURNISHED AND INSTALLED MUST COMPLY WITH THE PENNSYLVANIA STEEL PRODUCTS PROCUREMENT ACT.
4. ANY MODIFICATION MUST BE APPROVED BY THE EWW ENGINEERING DEPARTMENT IN ADVANCE.
5. CASING THICKNESS MAY BE INCREASED AS APPLICATIONS AND CONDITIONS WARRANT AND AT THE SOLE DISCRETION OF EWW.

DRAWN BY: RD	APPROVED BY: CP
DATE: FEB 2020	EWV - CD - 010

# STEEL CASING AND DUCTILE IRON WATER MAIN (BORE)

**ERIE WATER WORKS**  
 240 West 12th Street  
 Erie, PA 16501  
[engineering@eriewaterworks.org](mailto:engineering@eriewaterworks.org)

