

## TEE - PLAN

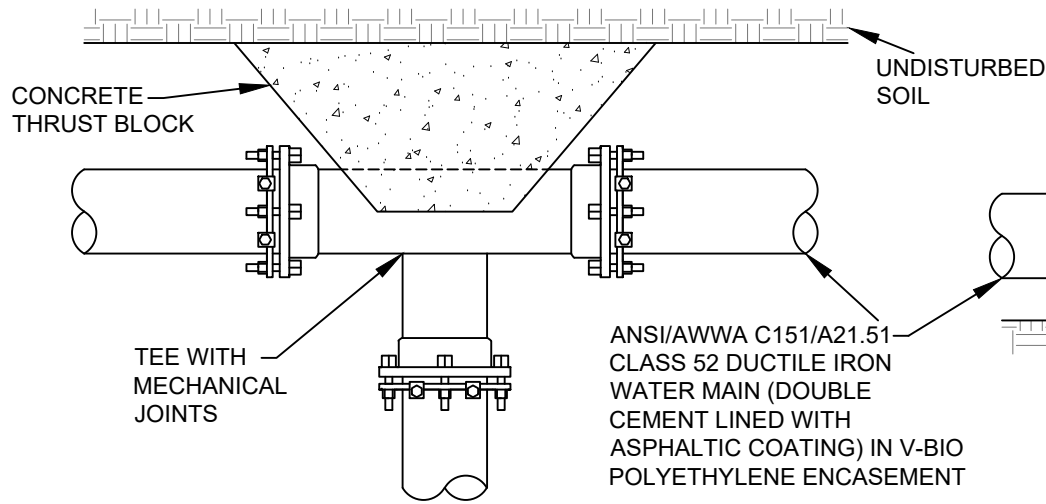

## VERTICAL BEND UP - ELEVATION

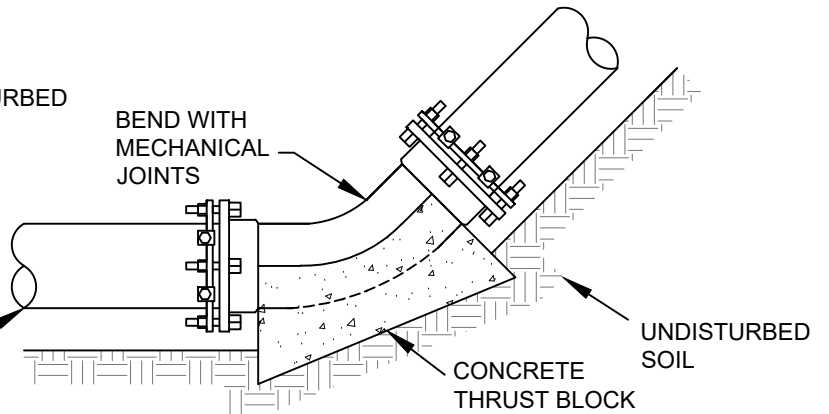

### NOTES:

1. PENNDOT CLASS A CONCRETE SHALL BE USED FOR THRUST BLOCKS.
2. CONCRETE MUST BEAR UPON UNDISTURBED SOIL.
3. ROUGH FORMS SHALL BE USED TO CONTAIN CONCRETE FOR THRUST BLOCKS. MECHANICAL JOINTS ARE NOT TO BE COVERED.
4. ALLOW POURED CONCRETE THRUST BLOCKS TO SET PRIOR TO BACKFILLING.
5. ALL PIPE AND FITTINGS TO BE WRAPPED IN V-BIO POLYETHYLENE ENCASEMENT.
6. ALL FITTINGS ARE TO BE MECHANICALLY RESTRAINED.
7. ALL BOLTS, NUTS, AND WASHERS EXPOSED TO DIRECT BURY CONDITIONS SHALL BE LOW ALLOY STEEL. AFTER ASSEMBLY ALL BOLTS, NUTS, AND WASHERS SHALL BE COMPLETELY COATED WITH SPRAY ON CORROSION PROTECTION AND BOLTS SHALL BE EQUIPPED WITH SACRIFICIAL ZINC ANODE CAPS (MANUFACTURED BY TRUMBULL OR APPROVED EQUAL).
8. MECHANICAL JOINT RESTRAINTS (1100 MEGALUG, MANUFACTURED BY EBBA IRON OR APPROVED EQUAL) AND CONCRETE THRUST BLOCKS ARE TO BE USED AS DEPICTED.
9. LOCK TYPE GASKETS (U.S. PIPE FIELD LOCK GASKETS OR APPROVED EQUAL) SHALL BE INSTALLED FOR 40' TO EITHER SIDE OF ALL FITTINGS.
10. ALL PIPES, FITTINGS, AND FIXTURES IN CONTACT WITH POTABLE WATER SHALL BE LEAD FREE PER THE REDUCTION OF LEAD IN DRINKING WATER ACT AND NSF / ANSI STANDARD 61 (NSF-61). LEAD FREE IS DEFINED AS CONTAINING NOT MORE THAN A WEIGHTED AVERAGE OF 0.25 PERCENT LEAD WHEN USED WITH RESPECT TO THE WETTED SURFACES OF PIPES, PIPE FITTINGS, PLUMBING FITTINGS, AND FIXTURES.
11. ALL MATERIALS FURNISHED AND INSTALLED MUST COMPLY WITH THE PENNSYLVANIA STEEL PRODUCTS PROCUREMENT ACT.
12. ANY MODIFICATION MUST BE APPROVED BY THE EWW ENGINEERING DEPARTMENT IN ADVANCE.

## VERTICAL BEND UP - SECTION

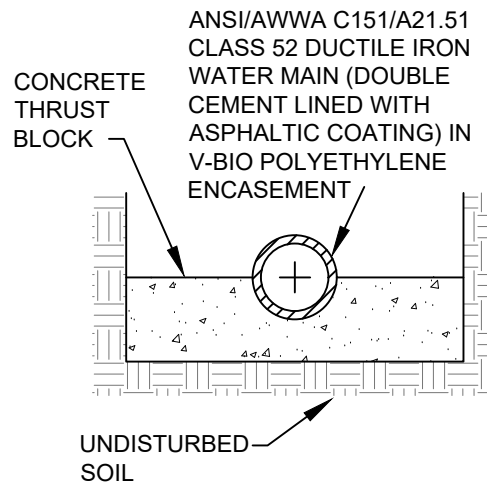

## TEE - ELEVATION

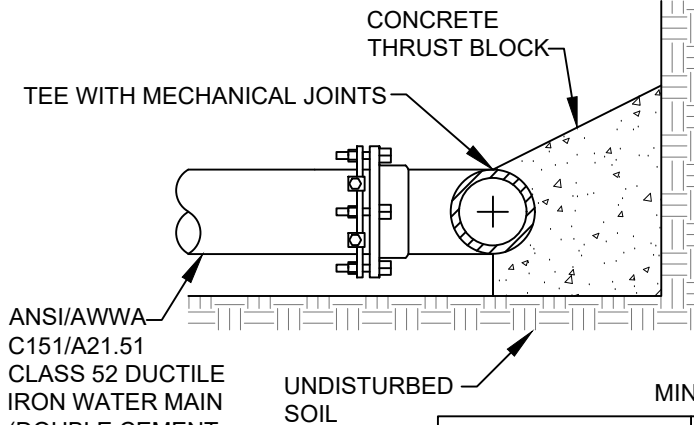

MINIMUM THRUST BLOCK SIZES

FITTINGS		3" OR 4"	6"	8"	10"	12"	16"
TEE	SF	1.2	2.4	4.0	7.0	9.0	14.0
VERTICAL BENDS UP							
1/4 (90) °	SF	1.3	3.0	4.6	7.0	10.0	17.0
1/8 (45) °	SF	1.0	1.5	2.5	4.0	5.4	9.2
1/16-1/32 (22 1/2 - 11 1/4) °	SF	1.0	1.2	2.0	3.1	3.6	5.5

(NOT TO SCALE)

DRAWN BY: HB	APPROVED BY: CE
DATE: MAR 2024	EWV - CD - 015

## CONCRETE THRUST BLOCKING (2 OF 3)

**ERIE WATER WORKS**  
240 West 12th Street  
Erie, PA 16501  
engineering@eriewaterworks.org

